

Comparison Chart

OVERALL FEATURES	DuraMAX	DuraMAX RC	DuraMAX BiTurbo T2	DuraMAX Duo Jr	DuraMAX Duo	DuraMAX Trio
· Engineered for Pool Lengths up to	80'	80'	100'	120'	150'	250'
· Any Surface Type (Tile – Steel – Vinyl – Aggregate)	✓	✓	✓	✓	✓	✓
· Any Configuration (River – L – Freeform – Rectangle)	✓	✓	✓	✓	✓	✓
· Maximum GPH Filtration / Circulation	6,000	6,000	12,000	12,000	12,000	18,000
· Maximum Filter Debris Holding Capacity	45 Qts	45 Qts	45 Qts	45 Qts	68 Qts	102 Qts
· Floor & Wall Cleaning Modes	✓	✓	✓	✓	✓	n/a
· Floor Only Cleaning Modes	n/a	✓	✓	✓	✓	✓
· Patented Power Washing Jets	n/a	n/a	n/a	n/a	✓	✓
· EasyService™ Quick Disconnections	✓	✓	✓	✓	✓	✓
· Dual-Directional Wireless Remote Control	✓	n/a	✓	n/a	n/a	n/a
· 4-Directional Wireless Remote Control	n/a	✓	n/a	✓	✓	✓
· Beach Boy Air Sensor	✓	✓	✓	✓	✓	✓
· InfraRed Sensor **	n/a	n/a	n/a	n/a	‡	‡
· Raised InfraRed Sensor **	n/a	n/a	n/a	n/a	‡	‡
· Patented BodyGUARD™ Corner Wheels	✓	✓	✓	✓	✓	✓
· DeepClean™ Super Brushes	✓	✓	✓	✓	✓	✓
· Lightweight Thermoplastic Encased Durable Two Wire Floating Cord Length	120'	120'	120'	120' / 150'	120' / 150'	150' †
· Customizable 1-7 Hrs. + Continuous Mode Auto-Shut Off Timer	✓	✓	✓	✓	✓	n/a
· 2 Year Warranty	✓	✓	✓	✓	✓	✓
· Total Unit Weight	33 lbs	35 lbs	37 lbs	41 lbs	47 lbs	65 lbs
· Total Shipping Weight	64 lbs	69 lbs	68 lbs	72 lbs	75 lbs	107 lbs

† 4 Wire Floating Cord

‡ Optional

** Infrared Obstacle Detection Sensor: Available on new DuraMAX Duo and Trio models for unique obstacles, such as raised safety ledges and bulkheads.

For more information, to view product videos or for recommendations on product for your specific aquatic maintenance needs, please contact us directly or your local distributor.



25 Rutgers Avenue, Cedar Grove, New Jersey 07009
 Tel: 800-221-1750 • Fax: 866-829-8126
 Email: Commercial@AquaProducts.com
 Web: www.AquaProducts.com/DuraMAX



DURABILITY. PERFORMANCE. RELIABILITY.



About DuraMAX...

The DuraMAX® product line is a direct result of nearly 30 years experience of over 1,000,000 robotic cleaners sold globally. The culmination of wear and tear, harsh environment, aggregate surfaces and multiple pool application conditions were all taken into account in the total design process. Engineered for maximum durability, reliability and performance DuraMAX® is the next generation of automatic aquatic maintenance. The following true professional grade features are now available standard on models within the DuraMAX® line.

DuraMAX Series Innovative Professional Grade Features	
• Patented Power Washing Jets (Flush Out Sand, Silt and Dust From Pores, Corners and Seams - Where Brushes Can't Reach)	• Durable Lightweight 120' / 150' Thermoplastic Rubber Encased 16 Gauge 1/2" Diameter 2 Wire Buoyant Cable (DuraMAX Trio: 3/4" (16 gauge, 4 wire) Cable)
• EasyService™ Watertight Quick Motor Disconnectors	• Each Body Contains a 34 / 45 Quart Capacity, High Strength, Mildew Resistant Reusable Microfilter Bag
• Wireless Remote Control (Guidance or Automatic Modes)	• Vacuum Port Extensions Lowers the Suction Points For Enhanced Removal of Embedded Dirt: Ideal for Porous Surfaces <i>(on select units)</i>
• Patented BodyGUARD™ Corner Wheels	• Vacuum Port Velocity Adjustment Increases Suction Flow: Ideal for Heavy Sand and Fine Silt and Pollen Removal <i>(on select units)</i>
• DuraTRAX™ Long Last Durable Direct-Drive Tracks	• Largest Debris Intake Ports of Any Cleaner Accommodate The Largest Debris and Are Offset To Avoid Clogging <i>(on select units)</i>
• Customizable Digital 1-7 Hrs. Auto-Shut Off Timer + Continuous Mode (n/a on DuraMAX Trio)	• NeverStuck™ Rollers with Center Concave Point for Traversing Anti-Entrapment Main Drains <i>(on select units)</i> (ASME/ANSI Standards Compliance Required), Return Fittings and Convex Lights
• Debris settling feature allows a programmable 1-hour delayed start	• Each is Equipped with UltraKart/UltraKart Jr. Stainless Steel Transportation / Storage Caddy
• Pre-programmed for Automatic Obstacle Detection	• Durable All Surface DeepClean™ Super Brushes (Optional PVA Tile/Steel/Surface-Specific Brushes Available)
• DuraMAX Harsh Environment Drive Train	• Zero Depth / Beach Entry Air Detection Sensor
• StayCool™ All-Weather-Resistant Power Supply	• '304' Stainless Steel 1/2" Diameter Full Length Axle Cores



Patented BodyGUARD™ Corner Wheels

DuraMAX Harsh Environment Drive Train

DuraTRAX™ Long Last Durable Direct Drive Tracks



All DurMAX cleaners come standard with EasyService™ Watertight Quick Motor Disconnections. This feature enables you to disconnect motor parts without messy splicing or damage to any important wires, enabling in-the-field on-the-spot motor replacement - without the need to send an entire cleaner out for service repair.

The patented efficient design of the power washing jet feature is along the same shaft of the pump motor's propeller resides an impeller with a small pump housing around it. This forces filtered water under high pressure to then be thrust through tubes to eject the water underneath the cleaner as HydroScrubbing power washing jets.

Vacuum Port Extensions lowers the suction points for enhanced removal of embedded dirt, silt and sand: ideal for porous surfaces

Power Washing/Hydroscrubbing Jets help push debris towards the intake ports.

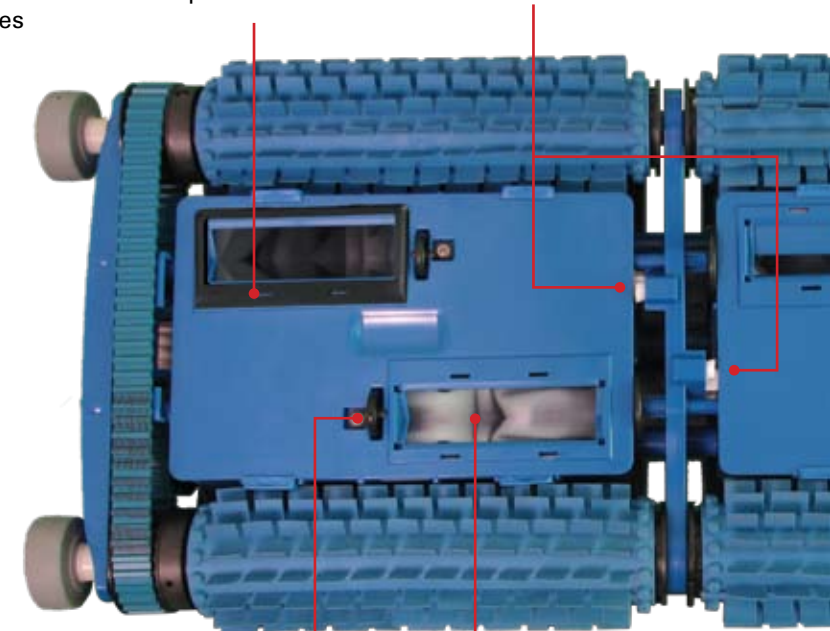

NeverStuck® rollers protect the undercarriage and roll over raised obstacles.

Each body contains a 34 / 45 Quart capacity, high strength, mildew Resistant Reusable Microfilter Bag and largest debris Intake Ports of any cleaner accommodate the largest debris and are offset to avoid clogging.

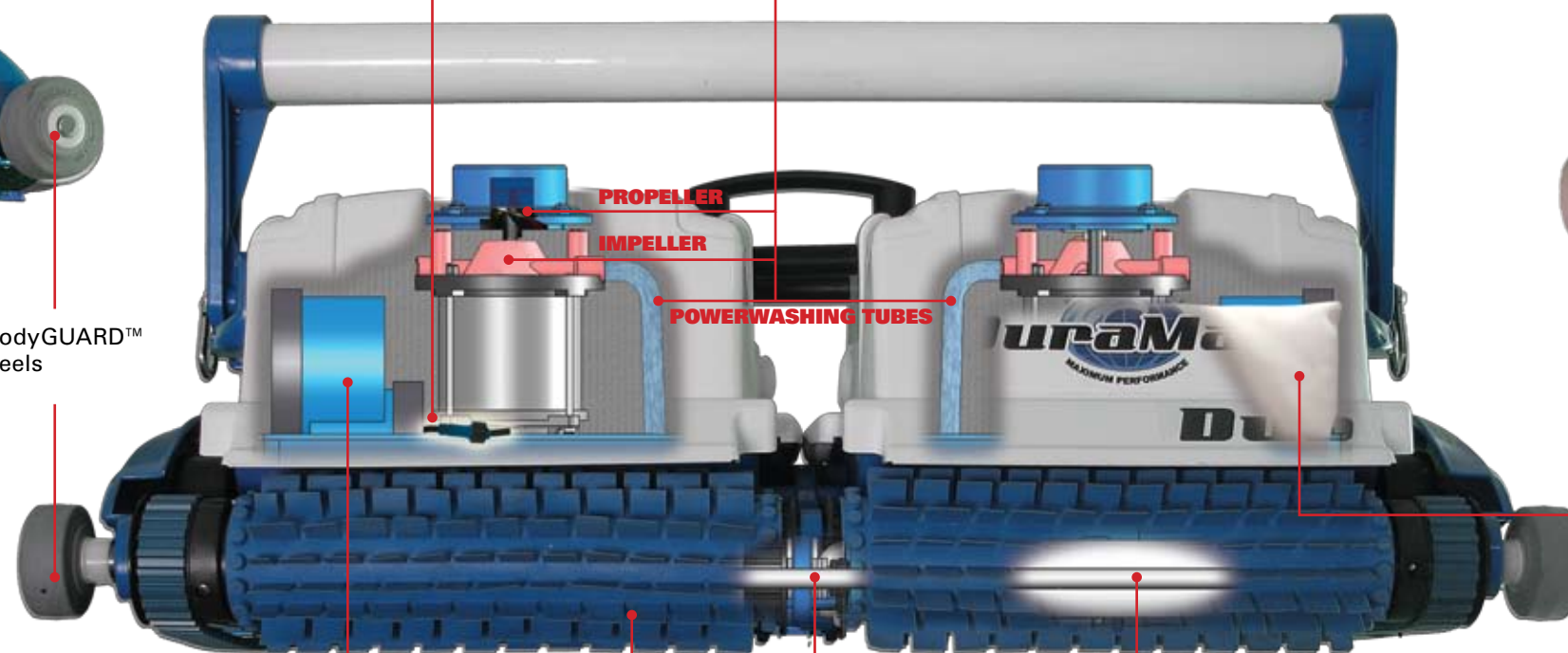

PROPELLER

IMPELLER

POWERWASHING TUBES

Separate Individually Sealed Single Pump and Two Drive Motors

All Surface DeepClean™ Super Brushes

'304' Stainless Steel 1/2" Diameter Full Length Axle Cores

Located on the inside of the bottom lid and near the vacuum intake port is the Vacuum Port Velocity Adjustment. If the selector switch is moved towards the "LESS" markings the inlet flaps will be kept from fully opening. This will increase the suction power of the cleaner, which is ideal for removal of fine silt and pollen and heavy sand.

DuraMax Product Line



DuraMAX

General Specifications

- Pools up to 80' long / All Surface Types (Tile – Steel – Vinyl – Aggregate)
- Any Configuration (River – L – Freeform – Rectangle)
- 45 Quarts Maximum Debris Holding Capacity Reusable Filter
- 6,000 GPH Maximum Filtration / Circulation
- Separate Individually Sealed Single Drive and Pump Motors
- Patented Arc Radius Floor-Turning (30% Greater Efficiency & All Shape Coverage)
- 3-Directional Wireless Remote Control (*Guidance or Automatic Modes*)
- 120' Floating Cord
- 33 Lbs. Unit Weight
- 2 Year Warranty
- 26" Length x 15" Width x 12" Height



DuraMAX RC

General Specifications

- Pools up to 80' long / All Surface Types (Tile – Steel – Vinyl – Aggregate)
- Any Configuration (River – L – Freeform – Rectangle)
- 45 Quarts Maximum Debris Holding Capacity Reusable Filter
- 6,000 GPH Maximum Filtration / Circulation
- Separate Individually Sealed Single Pump and Two Drive Motors
- 4-Directional Wireless Remote Control (*Guidance or Automatic Modes*)
- 120' Floating Cord
- Programmable 1 Hour Auto-Start Delay
- 37 Lbs. Unit Weight
- 2 Year Warranty
- 26" Length x 15" Width x 12" Height



DuraMAX BiTurbo T2

General Specifications

- Pools up to 100' long / All Surface Types (Tile – Steel – Vinyl – Aggregate)
- Any Configuration (River – L – Freeform – Rectangle)
- Heavy Bather / Debris Load Pool Maintenance
- 45 Quarts Maximum Debris Holding Capacity Reusable Filter
- 12,000 GPH Maximum Filtration / Circulation
- Separate Individually Sealed Single Drive and Two Pump Motors
- 4 Button, Dual-Directional Wireless Remote Control (*Guidance or Automatic Modes*)
- Patented Directional Guidance Clutch for Greater Efficiency & All Shape Coverage
- 120' Floating Cord
- Programmable 1 Hour Auto-Start Delay
- 37 Lbs. Unit Weight
- 2 Year Warranty
- 26" Length x 15" Width x 12" Height



DuraMAX Duo Jr

General Specifications

- Pools up to 120' long / All Surface Types (Tile – Steel – Vinyl – Aggregate)
- Any Configuration (River – L – Freeform – Rectangle)
- Heavy Bather / Debris Load Pool Maintenance
- 45 Quarts Maximum Debris Holding Capacity Reusable Filter
- 12,000 GPH Maximum Filtration / Circulation
- Separate Individually Sealed Two Drive and Two Pump Motors
- 4-Directional Wireless Remote Control (*Guidance or Automatic Modes*)
- 120' Floating Cord
- Programmable 1 Hour Auto-Start Delay
- 2 Year Warranty
- 41 Lbs. Unit Weight
- 26" Length x 15" Width x 12" Height



DuraMAX Duo

General Specifications

- Pools up to 150' long / All Surface Types (Tile – Steel – Vinyl – Aggregate)
- Any Configuration (River – L – Freeform – Rectangle)
- Heavy Bather / Debris Load Pool Maintenance
- 68 Quarts Maximum Debris Holding Capacity Reusable Filters
- 12,000 GPH Maximum Filtration / Circulation
- Separate Individually Sealed Two Drive and Two Pump Motors
- 4-Directional Wireless Remote Control (*Guidance or Automatic Modes*)
- 120' Floating Cord
- Patented Power Washing / Hydroscrubbing Jets
- Programmable 1 Hour Auto-Start Delay
- 47 Lbs. Unit Weight
- 2 Year Warranty
- 34" Length x 15" Width x 12" Height



DuraMAX Trio

General Specifications

- Pools Over 150' and up to 250' Long / Any Surface Types (Tile – Steel – Vinyl – Aggregate)
- Any Configuration (River – L – Freeform – Rectangle)
- Heavy Bather / Debris Load Pool Maintenance
- 102 Quarts Maximum Debris Holding Capacity Reusable Filters
- 18,000 GPH Maximum Filtration / Circulation
- Engineered For Maximum Durability & Reliability
- Programmable 1 Hour Auto-Start Delay
- 4-Directional Wireless Remote Control (*Guidance or Automatic Modes*)
- Separate Individually Sealed Two Drive and Three Pump Motors
- 150' Floating Cord
- Patented Power Washing / Hydroscrubbing Jets
- 65 Lbs. Unit Weight
- 2 Year Warranty
- 50" Length x 16" Width x 12" Height



"...Saves Labor
Time & Expense..."

"...A DuraMAX Solution
for Every Application..."

"...Saves Chemicals
& Water..."

"...Pays For Itself
In One Season..."

"...Individually Hand-Crafted
in the USA..."